

# Kugel- oder Pendelelektroden

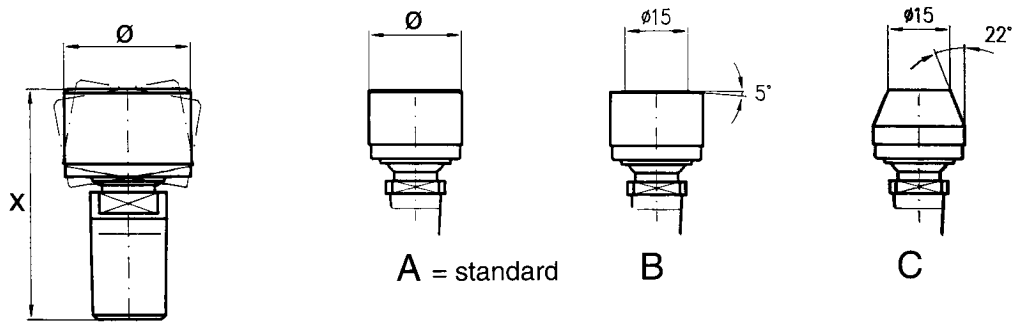

X	$\emptyset$	Kegel	Nr.	Bestellnummer
48	30	1:10 = 8.9	15	C153002A1-000
48	30	1:10 = 10	15	C153004A1-000
42	22	1:10 = 12	20	C202205A1-000
42	22	ISO13	20	C202230A1-000
50	30	1:10 = 12	20	C203005A1-000
55	22	1:10 = 17.78	35	C352206A1-000
55	30	1:10 = 17.78	35	C353006A1-000
61	22	ISO19	35	C352233A1-000
55	30	ISO16	35	C353038A1-000
42	22	MK1	43	C432209A1-000
50	30	MK1	43	C433009A1-000
55	22	MK2	58	C582210A1-000
55	30	MK2	58	C583010A1-000

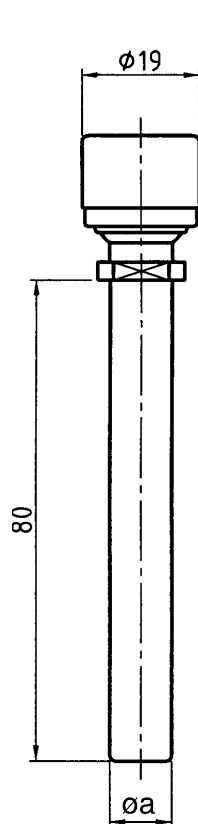

Speziell für luftgekühlte Punktschweißzangen.  
 $\emptyset a$  10 oder 12 mm

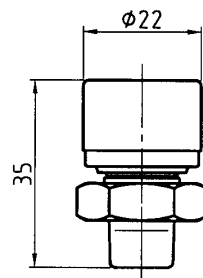

Sonderform mit Gewinde

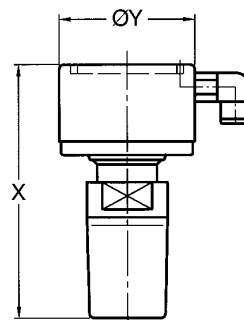

Spezielle Kugel- oder Pendelelektrode zum spurlosen Schweißen von Edelstahl.  
 Kühlung direkt oder indirekt möglich.

X	Y	Kegel	Nr.	Art.-Nummer
42	22	1:10=12	20	C202205A1-001
50	30	1:10=12	20	C203005A1-001
55	22	1:10=18	35	C352206A1-001
55	30	1:10=18	35	C353006A1-002
42	22	MK1	43	C432209A1-002
50	30	MK1	43	C433009A1-001
55	22	MK2	58	C582210A1-001
55	30	MK2	58	C583010A1-001